

# AND A/T INDICATOR (1UZ-FE)

\*1 : W/ TRACTION CONTROL  
 \*2 : W/O TRACTION CONTROL

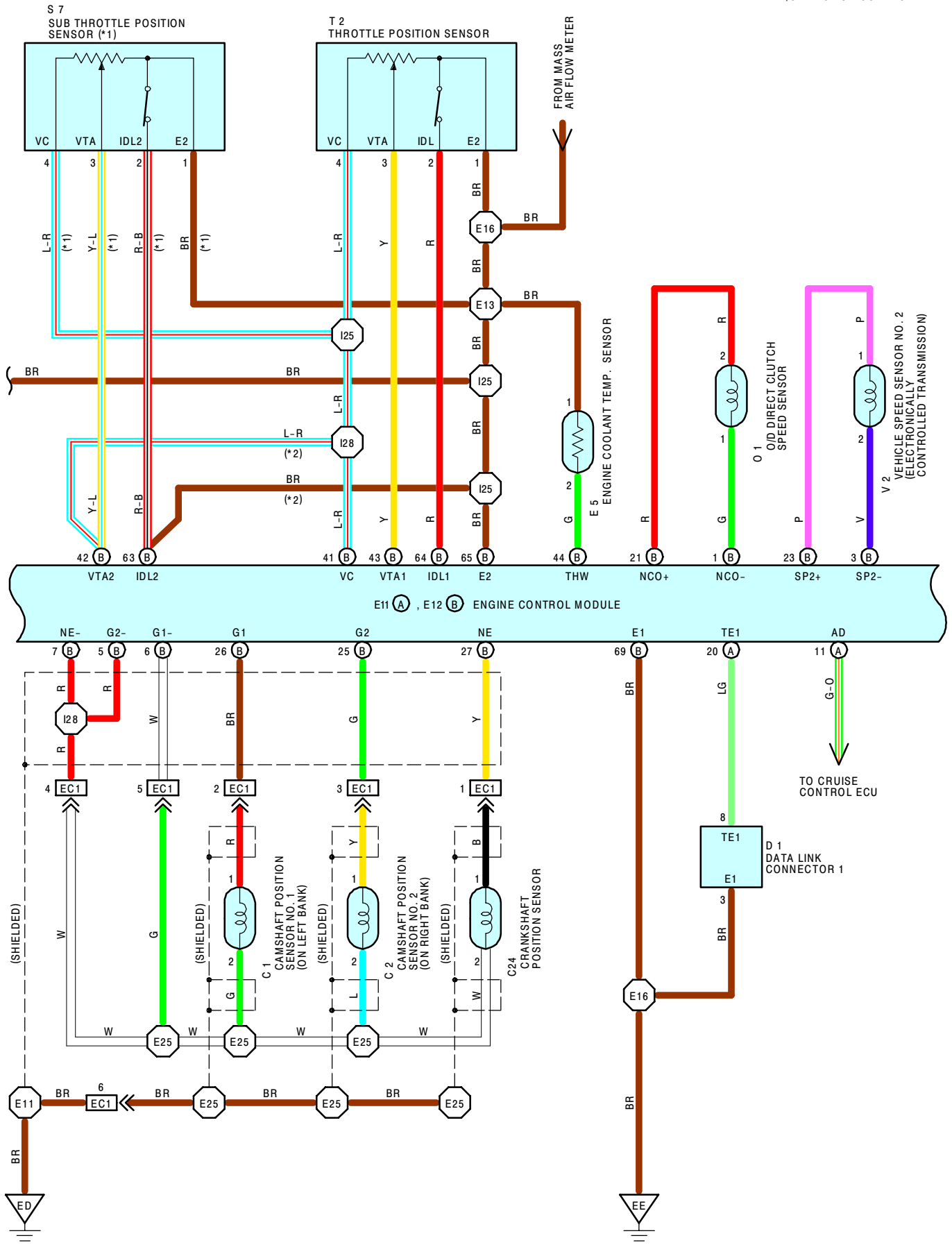

FROM POWER SOURCE SYSTEM (SEE PAGE 60)

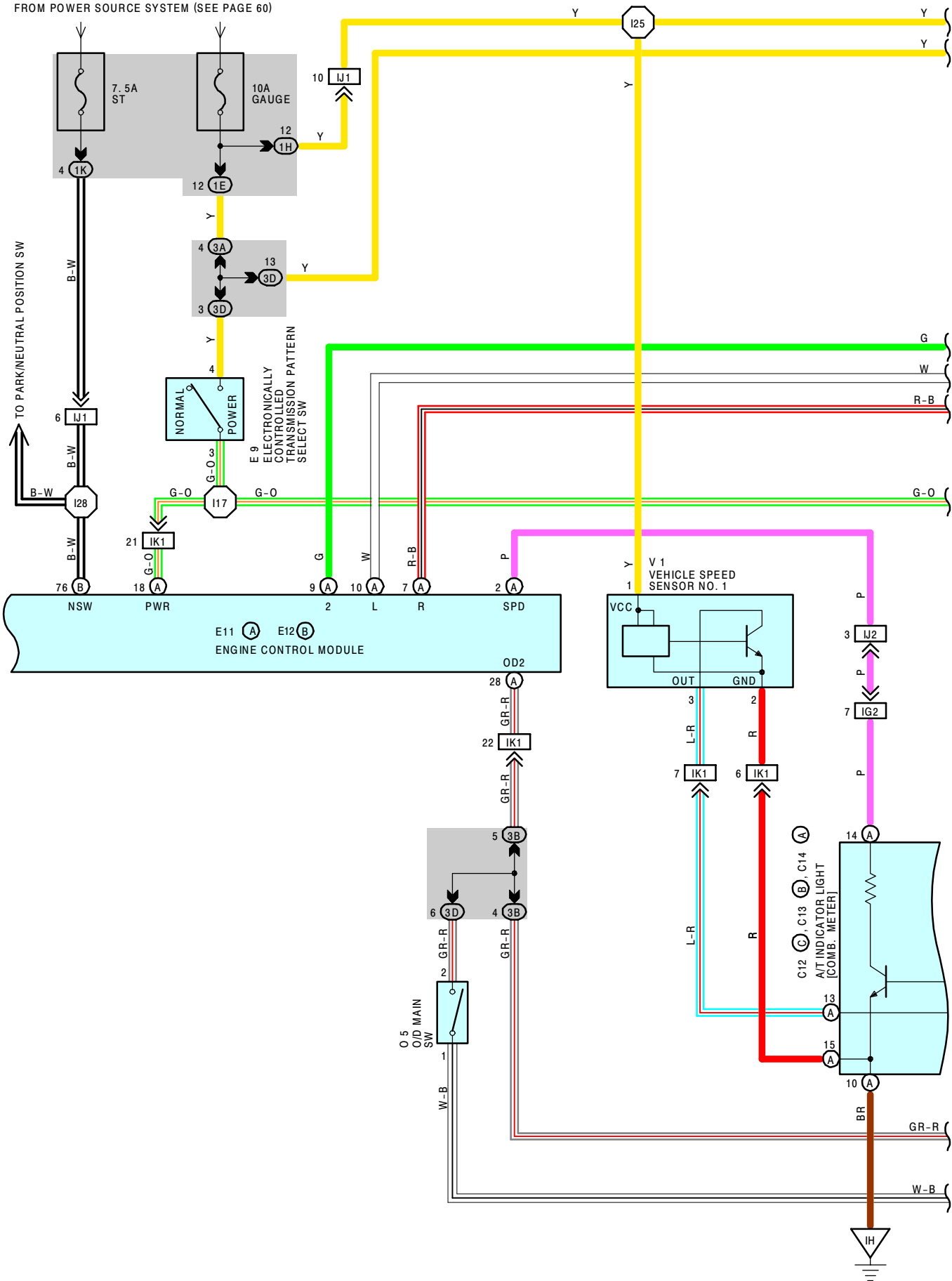

# AND A/T INDICATOR (1UZ-FE)

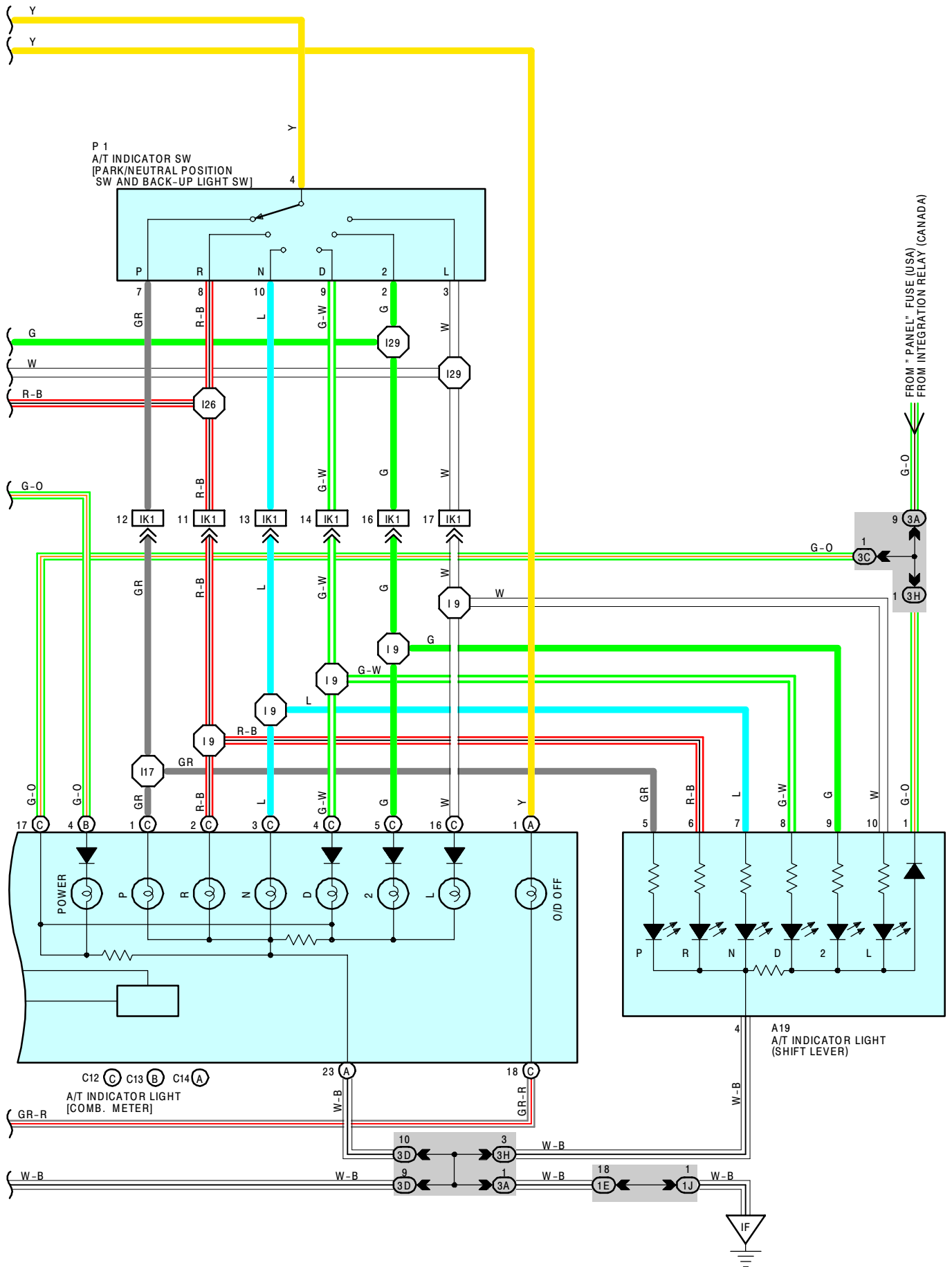

**SYSTEM OUTLINE**

THIS SYSTEM ELECTRICALLY CONTROLS THE LINE PRESSURE, THROTTLE PRESSURE, LOCK-UP PRESSURE AND ACCUMULATOR PRESSURE ETC. THROUGH THE SOLENOID VALVE. THE ELECTRONICALLY CONTROLLED TRANSMISSION IS A SYSTEM WHICH PRECISELY CONTROLS GEAR SHIFT TIMING AND LOCK-UP TIMING IN RESPONSE TO THE VEHICLE'S DRIVING CONDITIONS AND THE ENGINE OPERATING CONDITIONS DETECTED BY VARIOUS SENSORS, MAKING SMOOTH DRIVING POSSIBLE BY SHIFT SELECTION FOR EACH GEAR WHICH IS THE MOST APPROPRIATE TO THE DRIVING CONDITIONS AT THAT TIME, AND CONTROLS THE ENGINE TORQUE DURING SHIFTING TO ACHIEVE OPTIMUM SHIFT FEELING.

**1. GEAR SHIFT OPERATION**

DURING DRIVING, THE ENGINE WARM UP CONDITION IS INPUT AS A SIGNAL TO **TERMINAL (B) 44** OF THE ENGINE CONTROL MODULE FROM THE ENGINE COOLANT TEMP. SENSOR AND THE VEHICLE SPEED SIGNAL FROM THE VEHICLE SPEED SENSOR NO. 2 IS INPUT TO **TERMINAL (B) 23** OF THE ENGINE CONTROL MODULE. AT THE SAME TIME, THE THROTTLE VALVE OPENING SIGNAL FROM THE THROTTLE POSITION SENSOR (MAIN) IS INPUT TO **TERMINAL (B) 43** OF THE ENGINE CONTROL MODULE AS A THROTTLE ANGLE SIGNAL.

BASED ON THESE SIGNALS, THE ENGINE CONTROL MODULE SELECTS THE BEST SHIFT POSITION FOR DRIVING CONDITIONS AND SENDS CURRENT TO THE ELECTRONICALLY CONTROLLED TRANSMISSION SOLENOIDS.

WHEN SHIFTING TO THE 1ST SPEED, THE CURRENT FLOWS FROM **TERMINAL (B) 10** OF THE ENGINE CONTROL MODULE TO **TERMINAL 4** OF THE ELECTRONICALLY CONTROLLED TRANSMISSION SOLENOID → **GROUND**, AND CONTINUITY TO NO. 1 SOLENOID CAUSES THE SHIFT (NO. 2 SOLENOID DOES NOT HAVE CONTINUITY AT THIS TIME).

FOR THE 2ND SPEED, THE CURRENT FLOWS SIMULTANEOUSLY FROM **TERMINAL (B) 9** OF THE ENGINE CONTROL MODULE TO **TERMINAL 8** OF THE ELECTRONICALLY CONTROLLED TRANSMISSION SOLENOID → **GROUND**, AND FROM **TERMINAL (B) 10** OF THE ENGINE CONTROL MODULE TO **TERMINAL 4** OF THE ELECTRONICALLY CONTROLLED TRANSMISSION SOLENOID → **GROUND**, AND CONTINUITY TO NO. 1 AND NO. 2 SOLENOIDS CAUSES THE SHIFT.

FOR THE 3RD SPEED, THERE IS NO CONTINUITY TO NO. 1 SOLENOID, ONLY TO NO. 2 SOLENOID, CAUSING THE SHIFT.

SHIFTING INTO THE 4TH SPEED (OVERDRIVE) OCCURS WHEN NO CURRENT FLOW TO NO. 1 AND NO. 2 SOLENOIDS. THE NO. 4 SOLENOID (FOR ACCUMULATOR BACK PRESSURE MODULATION) IS INSTALLED TO ADJUST THE BACK PRESSURE ON THE ACCUMULATOR AND CONTROL THE HYDRAULIC PRESSURE DURING SHIFTING AND LOCK-UP IN ORDER TO PROVIDE SMOOTH SHIFTING WITH LITTLE SHIFT SHOCK.

**2. LOCK-UP OPERATION**

WHEN THE ENGINE CONTROL MODULE DECIDES, BASED ON EACH SIGNAL, THAT THE LOCK-UP CONDITION HAS BEEN MET, THE CURRENT FLOWS FROM **TERMINAL (B) 12** OF THE ENGINE CONTROL MODULE TO **TERMINAL 3** OF THE ELECTRONICALLY CONTROLLED TRANSMISSION SOLENOID → **TERMINAL 7** → **TERMINAL (B) 14** OF THE ENGINE CONTROL MODULE → **GROUND**, SO CONTINUITY TO NO. 3 SOLENOID (LOCK-UP) CAUSES LOCK-UP.

**3. STOP LIGHT SW CIRCUIT**

IF THE BRAKE PEDAL IS DEPRESSED (STOP LIGHT SW ON) WHEN DRIVING IN LOCK-UP CONDITION, A SIGNAL IS INPUT TO **TERMINAL (A) 4** OF THE ENGINE CONTROL MODULE. THE ENGINE CONTROL MODULE OPERATES AND CUTS THE CURRENT TO THE SOLENOID TO RELEASE LOCK-UP.

**4. OVERDRIVE CIRCUIT**

\* O/D MAIN SW ON

WHEN THE O/D MAIN SW IS TURNED ON (SW POINT IS OPEN), A SIGNAL IS INPUT TO **TERMINAL (A) 28** OF THE ENGINE CONTROL MODULE AND THE ELECTRONICALLY CONTROLLED TRANSMISSION CAUSES SHIFT TO OVERDRIVE WHEN THE CONDITIONS FOR OVERDRIVE ARE MET.

\* O/D MAIN SW OFF

WHEN THE O/D MAIN SW IS TURNED OFF (SW POINT IS CLOSED), THE CURRENT FLOWING THROUGH THE O/D OFF INDICATOR LIGHT FLOWS TO **GROUND** BY WAY OF THE O/D MAIN SW AND CAUSES THE O/D OFF INDICATOR LIGHT TO LIGHT UP. AT THE SAME TIME, A SIGNAL IS INPUT TO **TERMINAL (A) 28** OF THE ENGINE CONTROL MODULE AND THE ELECTRONICALLY CONTROLLED TRANSMISSION PREVENTS SHIFT INTO OVERDRIVE.

**5. ELECTRONICALLY CONTROLLED TRANSMISSION PATTERN SELECT SW CIRCUIT**

WHEN THE ELECTRONICALLY CONTROLLED TRANSMISSION PATTERN SELECT SW IS CHANGED FROM "NORMAL" TO "POWER", THE CURRENT THROUGH THE **GAUGE FUSE** FLOWS TO **TERMINAL 4** OF THE ELECTRONICALLY CONTROLLED TRANSMISSION PATTERN SELECT SW → **TERMINAL 3** → **TERMINAL (B) 4** OF THE A/T INDICATOR LIGHT → **TERMINAL (A) 23** → **GROUND** AND CAUSES THE INDICATOR LIGHT TO LIGHT UP. AT THE SAME TIME, THE CURRENT FLOWS TO **TERMINAL (A) 18** OF THE ENGINE CONTROL MODULE AND THE ENGINE CONTROL MODULE PERFORMS SHIFT UP AND SHIFT DOWN AT A HIGHER VEHICLE SPEED RANGE COMPARED WITH "NORMAL" POSITION.

**6. CRUISE CONTROL**

WHEN THE CRUISE CONTROL OPERATION IS SELECTED A SIGNAL IS INPUT TO **TERMINAL (A) 12** OF THE ENGINE CONTROL MODULE FROM CRUISE CONTROL ECU. AS A RESULT, THE ECU OPERATES AND CONTROLS OVERDRIVE, LOCK-UP AND SO ON FOR SMOOTH DRIVING.

# AND A/T INDICATOR (1UZ-FE)

## SERVICE HINTS

### E3 ELECTRONICALLY CONTROLLED TRANSMISSION SOLENOID

6-2 : 5.1-5.5  $\Omega$

7-3 : 3.5-3.9  $\Omega$

4, 8-GROUND : 10-16  $\Omega$

### E5 ENGINE COOLANT TEMP. SENSOR

1-2 : APPROX. 16.2 K $\Omega$  (-20°C, -4°F)

APPROX. 2.5 K $\Omega$  (20°C, 68°F)

APPROX. 0.32 K $\Omega$  (80°C, 176°F)

### E9 ELECTRONICALLY CONTROLLED TRANSMISSION PATTERN SELECT SW

4-3 : CLOSED WITH ELECTRONICALLY CONTROLLED TRANSMISSION PATTERN SW AT **POWER** POSITION

### E11 (A), E12 (B) ENGINE CONTROL MODULE

BATT -E1 : ALWAYS 9-14 VOLTS

+B -E1 : 9-14 VOLTS WITH IGNITION SW ON

IGSW -E1 : 9-14 VOLTS WITH IGNITION SW ON

MREL -E1 : 9-14 VOLTS WITH IGNITION SW ON

BK -E1 : 9-14 VOLTS WITH STOP LIGHT SW DEPRESSED

P -E1 : 9-14 VOLTS WITH IGNITION SW ON AND ELECTRONICALLY CONTROLLED TRANSMISSION PATTERN SELECT SW **POWER** POSITION

OD1 -E1 : 4-6 VOLTS WITH IGNITION SW ON

OD2 -E1 : 9-14 VOLTS WITH IGNITION SW ON AND O/D MAIN SW ON

NSW -E1 : 9-14 VOLTS WITH IGNITION SW ON AND SHIFT LEVER OTHER THAN **P** OR **N** POSITION

L -E1 : 9-14 VOLTS WITH IGNITION SW ON AND SHIFT LEVER **L** POSITION

2 -E1 : 9-14 VOLTS WITH IGNITION SW ON AND SHIFT LEVER **2** POSITION

R -E1 : 9-14 VOLTS WITH IGNITION SW ON AND SHIFT LEVER **R** POSITION

VTA -E2 : 3.2-4.9 VOLTS WITH IGNITION SW ON AND ACCEL PEDAL IS FULLY DEPRESSED

IDL1 -E2 : 9-14 VOLTS WITH IGNITION SW ON AND ACCEL PEDAL IS NOT DEPRESSED

### O1 O/D DIRECT CLUTCH SPEED SENSOR

1-2 : 560-680  $\Omega$

### V2 VEHICLE SPEED SENSOR NO. 2 (ELECTRONICALLY CONTROLLED TRANSMISSION)

1-2 : 560-680  $\Omega$

### S13 STOP LIGHT SW

2-1 : CLOSED WITH BRAKE PEDAL DEPRESSED



# ELECTRONICALLY CONTROLLED TRANSMISSION

## ○ : PARTS LOCATION

CODE	SEE PAGE	CODE	SEE PAGE	CODE	SEE PAGE
A19	30	D 1	26	O 5	31
C 1	26	E 3	26	P 1	27
C 2	26	E 5	26	S 7	27
C12	C 30	E 9	30	S13	31
C13	B 30	E11	A 30	T 2	27
C14	A 30	E12	B 30	V 1	27
C24	26	O 1	27	V 2	27

## ○ : RELAY BLOCKS

CODE	SEE PAGE	RELAY BLOCKS (RELAY BLOCK LOCATION)
2	19	R/B NO. 2

## ○ : JUNCTION BLOCK AND WIRE HARNESS CONNECTOR

CODE	SEE PAGE	JUNCTION BLOCK AND WIRE HARNESS (CONNECTOR LOCATION)
1E	20	INSTRUMENT PANEL WIRE AND J/B NO. 1 (LEFT KICK PANEL)
1H	20	COWL WIRE AND J/B NO. 1 (LEFT KICK PANEL)
1I		
1J		
1K		
3A	22	INSTRUMENT PANEL WIRE AND J/B NO. 3 (BEHIND THE INSTRUMENT PANEL CENTER)
3B		
3C		
3D		
3H		

## □ : CONNECTOR JOINING WIRE HARNESS AND WIRE HARNESS

CODE	SEE PAGE	JOINING WIRE HARNESS AND WIRE HARNESS (CONNECTOR LOCATION)
EB1	36 (1UZ-FE)	ENGINE WIRE AND ENGINE ROOM MAIN WIRE (FRONT SIDE OF R/B NO. 2)
EB2		
EC1	36 (1UZ-FE)	ENGINE WIRE AND ENGINE NO. 4 WIRE (FRONT SIDE OF CYLINDER HEAD COVER LH)
IG2	40	INSTRUMENT PANEL WIRE AND COWL WIRE (R/B NO. 5)
IJ1	40	ENGINE WIRE AND COWL WIRE (RIGHT KICK PANEL)
IJ2		
IK1	40	ENGINE WIRE AND INSTRUMENT PANEL WIRE (RIGHT KICK PANEL)

## ▽ : GROUND POINTS

CODE	SEE PAGE	GROUND POINTS LOCATION
EB	36 (1UZ-FE)	FRONT SIDE OF LEFT FENDER
ED	36 (1UZ-FE)	REAR SIDE OF CYLINDER HEAD RH
EE	36 (1UZ-FE)	REAR SIDE OF CYLINDER HEAD LH
IF	40	LEFT KICK PANEL
IH	40	UNDER THE ASHTRAY LH

## ○ : SPLICE POINTS

CODE	SEE PAGE	WIRE HARNESS WITH SPLICE POINTS	CODE	SEE PAGE	WIRE HARNESS WITH SPLICE POINTS
E11	36 (1UZ-FE)	ENGINE WIRE	I17	42	INSTRUMENT PANEL WIRE
E13			I25	42	ENGINE WIRE
E16			I26		
E25	36 (1UZ-FE)	ENGINE NO. 4 WIRE	I28		
I 9	42	INSTRUMENT PANEL WIRE	I29		

A19

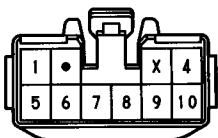

C 1 DARK GRAY



C 2 DARK GRAY



C12 Ⓢ

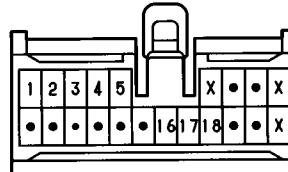

# AND A/T INDICATOR (1UZ-FE)

C13 (B)

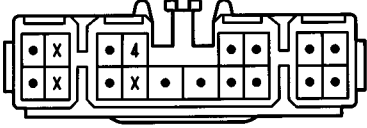

C14 (A)

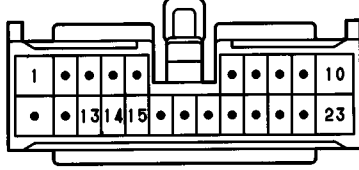

C24 DARK GRAY



D 1 BLACK

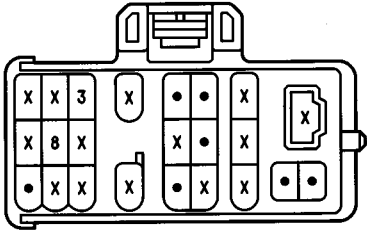

E 3 GRAY



E 5 GREEN



E 9 BROWN

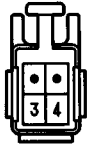

E11 (A) DARK GRAY

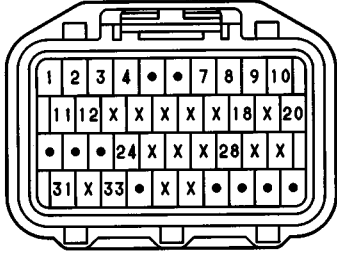

E12 (B) DARK GRAY

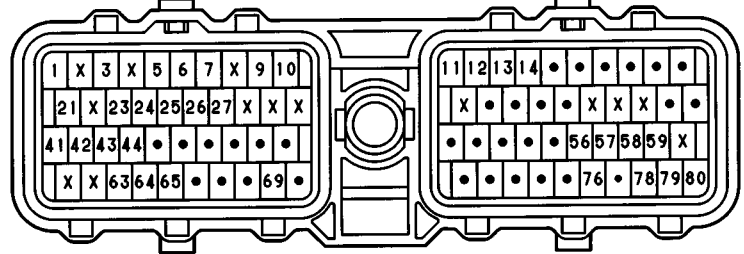

O 1 BLACK

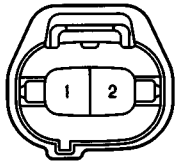

O 5

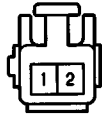

P 1 GRAY

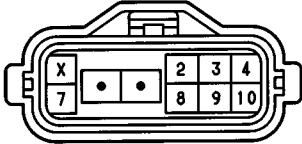

S 7 BLACK



S13

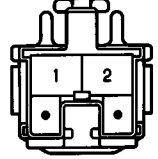

T 2 BLACK

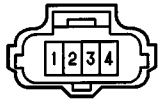

V 1 GRAY



V 2 BLACK

