



ENGINE CONTROL (1UZ-FE)

SYSTEM OUTLINE

THE ENGINE CONTROL SYSTEM UTILIZES A MICROCOMPUTER AND MAINTAINS OVERALL CONTROL OF THE ENGINE, TRANSMISSION, ETC. AN OUTLINE OF THE ENGINE CONTROL IS GIVEN HERE.

1. INPUT SIGNALS

(1) ENGINE COOLANT TEMP. SIGNAL CIRCUIT

THE ENGINE COOLANT TEMP. SENSOR DETECTS THE ENGINE COOLANT TEMP. AND HAS A BUILT-IN THERMISTOR WITH A RESISTANCE WHICH VARIES ACCORDING TO THE ENGINE COOLANT TEMP. IS INPUT INTO **TERMINAL THW** OF THE ENGINE CONTROL MODULE AS A CONTROL SIGNAL.

(2) INTAKE AIR TEMP. SIGNAL CIRCUIT

THE INTAKE AIR TEMP. SENSOR IS INSTALLED IN THE MASS AIR FLOW METER AND DETECTS THE INTAKE AIR TEMP., WHICH IS INPUT AS A CONTROL SIGNAL TO **TERMINAL THA** OF THE ENGINE CONTROL MODULE.

(3) OXYGEN DENSITY SIGNAL CIRCUIT

THE OXYGEN DENSITY IN THE EXHAUST EMISSION IS DETECTED AND INPUT AS A CONTROL SIGNAL FROM THE HEATED OXYGEN SENSORS (BANK 1 SENSOR 1, BANK 2 SENSOR 1) TO **TERMINALS OXL1, OXR1** OF THE ENGINE CONTROL MODULE AND FROM THE HEATED OXYGEN SENSORS (BANK 1 SENSOR 2, BANK 2 SENSOR 2) TO **TERMINALS OXL2, OXR2** OF THE ENGINE CONTROL MODULE. TO STABILIZE DETECTION PERFORMANCE BY THE HEATED OXYGEN SENSOR, THE HEATED OXYGEN SENSOR IS WARMED.

(4) RPM SIGNAL CIRCUIT

CAMSHAFT POSITION IS DETECTED BY THE CAMSHAFT POSITION SENSORS (LEFT AND RIGHT BANK) AND THE SIGNAL IS INPUT INTO **TERMINALS G1** AND **G2** OF THE ENGINE CONTROL MODULE AS A CONTROL SIGNAL. ALSO, THE ENGINE SPEED IS DETECTED BY THE CRANKSHAFT POSITION SENSOR INSTALLED IN THE CYLINDER BLOCK AND THE SIGNAL IS INPUT INTO **TERMINAL NE** OF THE ENGINE CONTROL MODULE AS A CONTROL SIGNAL.

(5) THROTTLE POSITION SIGNAL CIRCUIT

THE THROTTLE POSITION SENSOR DETECTS THE THROTTLE VALVE OPENING ANGLE AS A CONTROL SIGNAL, WHICH IS INPUT INTO **TERMINAL VTA1** OF THE ENGINE CONTROL MODULE. WHEN THE VALVE IS COMPLETELY CLOSED, THE CONTROL SIGNAL IS INPUT INTO **TERMINAL IDL1**.

(6) VEHICLE SPEED CIRCUIT

THE VEHICLE SPEED IS DETECTED BY THE VEHICLE SPEED SENSOR NO. 1 INSTALLED IN THE TRANSMISSION AND THE SIGNAL IS INPUT TO **TERMINAL SPD** OF THE ENGINE CONTROL MODULE VIA THE COMBINATION METER.

(7) NEUTRAL POSITION SIGNAL CIRCUIT

THE PARK/NEUTRAL POSITION SW DETECTS WHETHER THE SHIFT POSITION IS IN "N" AND "P" OR NOT, AND THE SIGNAL IS INPUT INTO **TERMINAL NSW** OF THE ENGINE CONTROL MODULE.

(8) A/C SW SIGNAL CIRCUIT

THE OPERATING VOLTAGE OF THE A/C MAGNETIC CLUTCH IS DETECTED AND THE SIGNAL IS INPUT INTO **TERMINAL ACMG** OF THE ENGINE CONTROL MODULE AS A CONTROL SIGNAL.

(9) BATTERY SIGNAL CIRCUIT

VOLTAGE IS CONSTANTLY APPLIED TO **TERMINAL BATT** OF THE ENGINE CONTROL MODULE. WITH THE IGNITION SW TURNED ON, THE VOLTAGE FOR ENGINE CONTROL MODULE START-UP POWER SUPPLY IS APPLIED TO **TERMINAL +B** OF THE ENGINE CONTROL MODULE VIA THE EFI MAIN RELAY.

THE CURRENT FLOWING THROUGH THE **IGN** FUSE FLOWS TO **TERMINAL IGSW** OF THE ENGINE CONTROL MODULE.

(10) INTAKE AIR VOLUME SIGNAL CIRCUIT

INTAKE AIR VOLUME IS DETECTED BY THE MASS AIR FLOW METER AND THE SIGNAL IS INPUT INTO **TERMINAL VG** OF THE ENGINE CONTROL MODULE AS A CONTROL SIGNAL.

(11) STOP LIGHT SW SIGNAL CIRCUIT

THE STOP LIGHT SW IS USED TO DETECT WHETHER OR NOT THE VEHICLE IS BRAKING AND THE SIGNAL IS INPUT INTO **TERMINAL BK** OF THE ENGINE CONTROL MODULE AS A CONTROL SIGNAL.

(12) STARTER SIGNAL CIRCUIT

TO CONFIRM WHETHER THE ENGINE IS CRANKING, THE VOLTAGE APPLIED TO THE STARTER MOTOR DURING CRANKING IS DETECTED AND THE SIGNAL IS INPUT INTO **TERMINAL STA** OF THE ENGINE CONTROL MODULE AS A CONTROL SIGNAL.

(13) ENGINE KNOCK SIGNAL CIRCUIT

ENGINE KNOCKING IS DETECTED BY THE KNOCK SENSOR NO. 1 AND NO. 2, AND THE SIGNAL IS INPUT INTO **TERMINALS KNK1** AND **KNK2** AS A CONTROL SIGNAL.

2. CONTROL SYSTEM

* SEQUENTIAL MULTIPOINT FUEL INJECTION SYSTEM

THE SEQUENTIAL MULTIPOINT FUEL INJECTION SYSTEM MONITORS THE ENGINE CONDITION THROUGH THE SIGNALS INPUT FROM EACH SENSOR (INPUT SIGNALS (1) TO (13)) TO THE ENGINE CONTROL MODULE. THE BEST FUEL INJECTION TIMING IS DECIDED BASED ON THIS DATA AND THE PROGRAM MEMORIZED BY THE ENGINE CONTROL MODULE, AND THE CONTROL SIGNAL IS OUTPUT TO **TERMINALS #10, #20, #30, #40, #50, #60, #70, AND #80** OF THE ENGINE CONTROL MODULE TO OPERATE THE INJECTOR. (INJECT THE FUEL). THE SEQUENTIAL MULTIPOINT FUEL INJECTION SYSTEM PRODUCES CONTROL OF FUEL INJECTION OPERATION BY THE ENGINE CONTROL MODULE IN RESPONSE TO THE DRIVING CONDITIONS.

* ESA (ELECTRONIC SPARK ADVANCE) SYSTEM

THE ESA SYSTEM MONITORS THE ENGINE CONDITION THROUGH THE SIGNALS INPUT TO THE ENGINE CONTROL MODULE FROM EACH SENSOR (INPUT SIGNALS (1), (2), (4), TO (13)). THE BEST IGNITION TIMING IS DECIDED ACCORDING TO THIS DATA AND THE MEMORIZED DATA IN THE ENGINE CONTROL MODULE AND THE CONTROL SIGNAL IS OUTPUT TO **TERMINALS IGT1 AND IGT2**. THIS SIGNAL CONTROLS THE IGNITER TO PROVIDE THE BEST IGNITION TIMING FOR THE DRIVING CONDITIONS.

* FUEL PRESSURE UP SYSTEM

THE FUEL PRESSURE UP SYSTEM CAUSES THE VSV (FUEL PRESSURE UP) TO COME ON FOR HIGH TEMP. STARTING AND INCREASED THE FUEL PRESSURE TO IMPROVE STARTABILITY AT HIGH TEMPERATURES AND TO PROVIDE STABLE IDLING. THE ENGINE CONTROL MODULE EVALUATES THE INPUT SIGNALS FROM EACH SENSOR ((1), (2), (4), (9) AND (10)), AND CURRENT IS OUTPUT TO **TERMINAL PR** OF THE ENGINE CONTROL MODULE TO CONTROL THE VSV.

* HEATED OXYGEN SENSOR HEATER CONTROL SYSTEM

THE HEATED OXYGEN SENSOR HEATER CONTROL SYSTEM TURNS THE HEATER ON WHEN THE INTAKE AIR VOLUME IS LOW (TEMP. OF EXHAUST EMISSIONS IS LOW), AND WARMS UP THE HEATED OXYGEN SENSOR TO IMPROVE DETECTION PERFORMANCE OF THE SENSOR.

THE ENGINE CONTROL MODULE EVALUATES THE SIGNALS FROM EACH SENSOR (INPUT SIGNALS (1), (2), (4), (9) TO (11)), AND OUTPUTS CURRENT TO **TERMINALS HTL1, HTR1, HTL2, AND HTR2** TO CONTROL THE HEATER.

* IDLE AIR CONTROL SYSTEM

THE IDLE AIR CONTROL SYSTEM (STEP MOTOR TYPE) INCREASES THE ENGINE SPEED AND PROVIDES IDLING STABILITY FOR FAST IDLE-UP WHEN THE ENGINE IS COLD, AND WHEN THE IDLE SPEED HAS DROPPED DUE TO ELECTRICAL LOAD AND SO ON. THE ENGINE CONTROL MODULE EVALUATES THE SIGNALS FROM EACH SENSOR (INPUT SIGNALS (1), (4), (5), (8), (9), (11)), OUTPUTS CURRENT TO **TERMINALS ISC1, ISC2, ISC3 AND ISC4** TO CONTROL THE IDLE AIR CONTROL VALVE.

* EGR CONTROL SYSTEM

THE EGR CONTROL SYSTEM DETECTS THE SIGNALS FROM EACH SENSOR (INPUT SIGNALS (1), (4), (9), (10)), AND OUTPUTS CURRENT TO **TERMINALS EGR1, EGR2, EGR3 AND EGR4** TO CONTROL THE EGR VALVE.

* FUEL PUMP CONTROL SYSTEM

THE ENGINE CONTROL MODULE OUTPUTS CURRENT TO **TERMINAL FPC** AND CONTROLS THE FUEL PUMP ECU AND FUEL PUMP DRIVE SPEED IN RESPONSE TO CONDITIONS.

3. DIAGNOSIS SYSTEM

WITH THE DIAGNOSIS SYSTEM, WHEN THERE IS A MALFUNCTION IN THE ENGINE CONTROL MODULE SIGNAL SYSTEM, THE MALFUNCTIONING SYSTEM IS RECORDED IN THE MEMORY. THE MALFUNCTIONING SYSTEM CAN BE FOUND BY READING THE CODE DISPLAYED BY THE MALFUNCTION INDICATOR LAMP.

4. FAIL-SAFE SYSTEM

WHEN A MALFUNCTION HAS OCCURRED IN ANY SYSTEMS, IF THERE IS A POSSIBILITY OF ENGINE TROUBLE BEING CAUSED BY CONTINUED CONTROL BASED ON THE SIGNALS FROM THAT SYSTEM, THE FAIL-SAFE SYSTEM EITHER CONTROLS THE SYSTEM BY USING DATA (STANDARD VALUES) RECORDED IN THE ENGINE CONTROL MODULE MEMORY OR ELSE STOPS THE ENGINE.



ENGINE CONTROL (1UZ-FE)

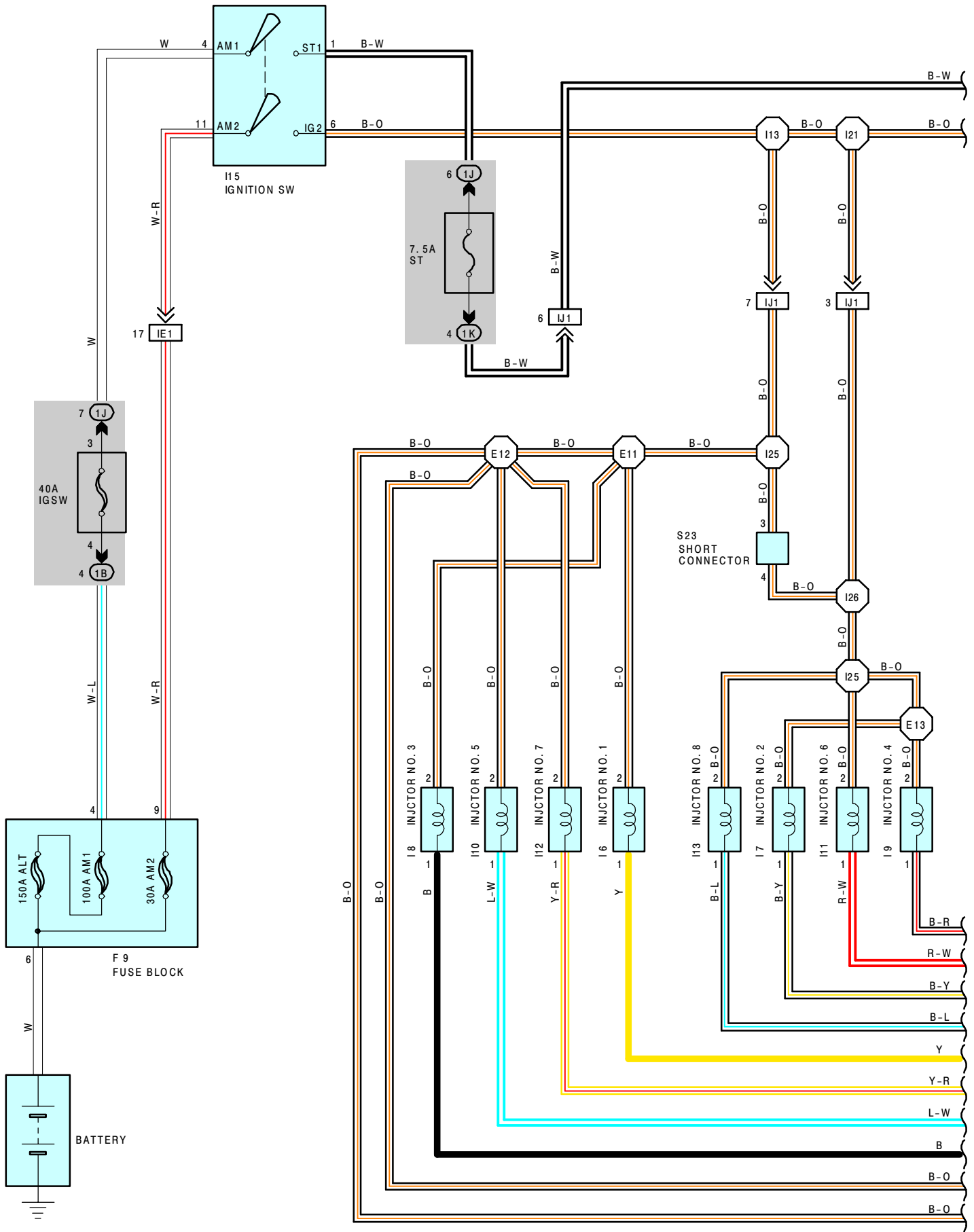

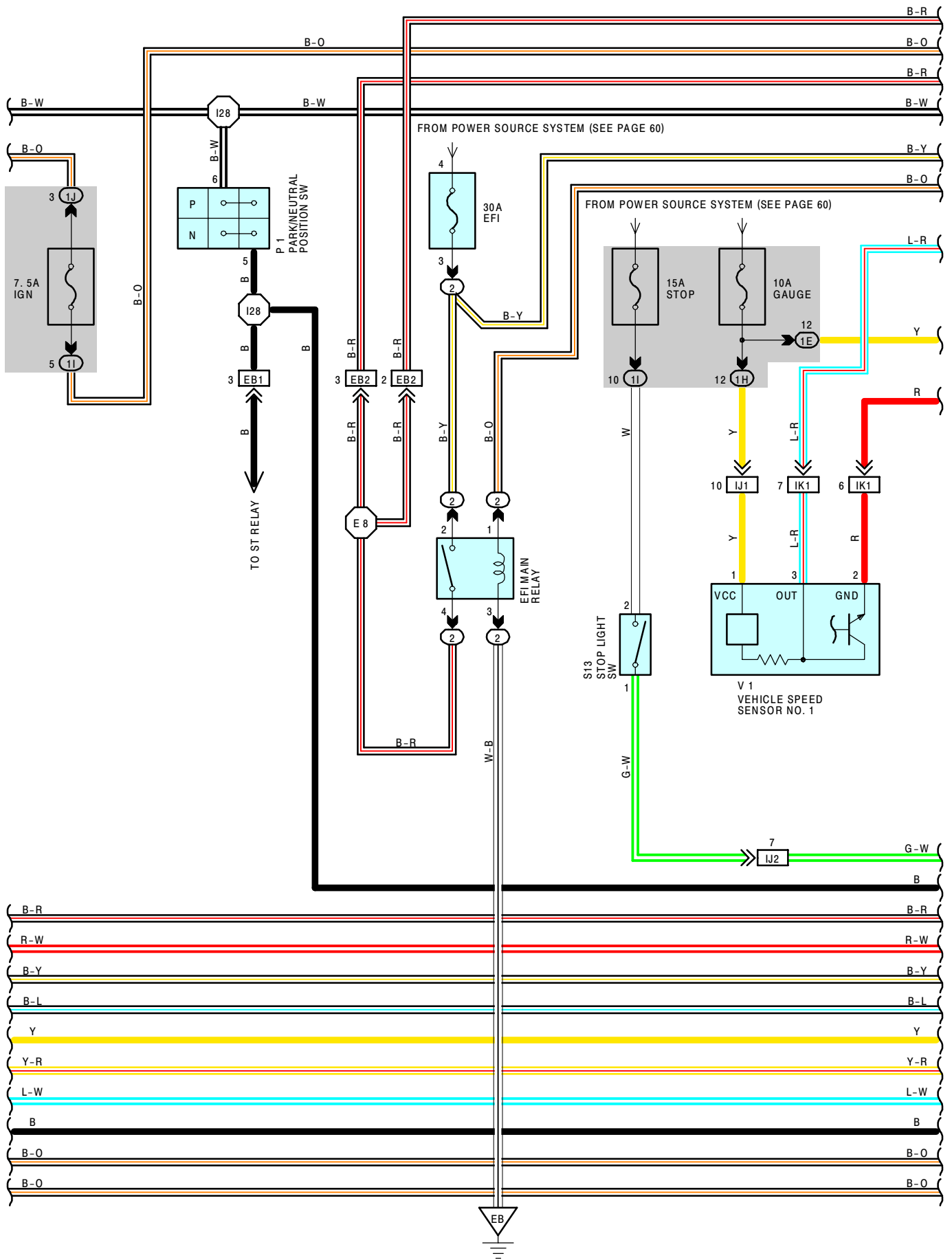



ENGINE CONTROL (1UZ-FE)

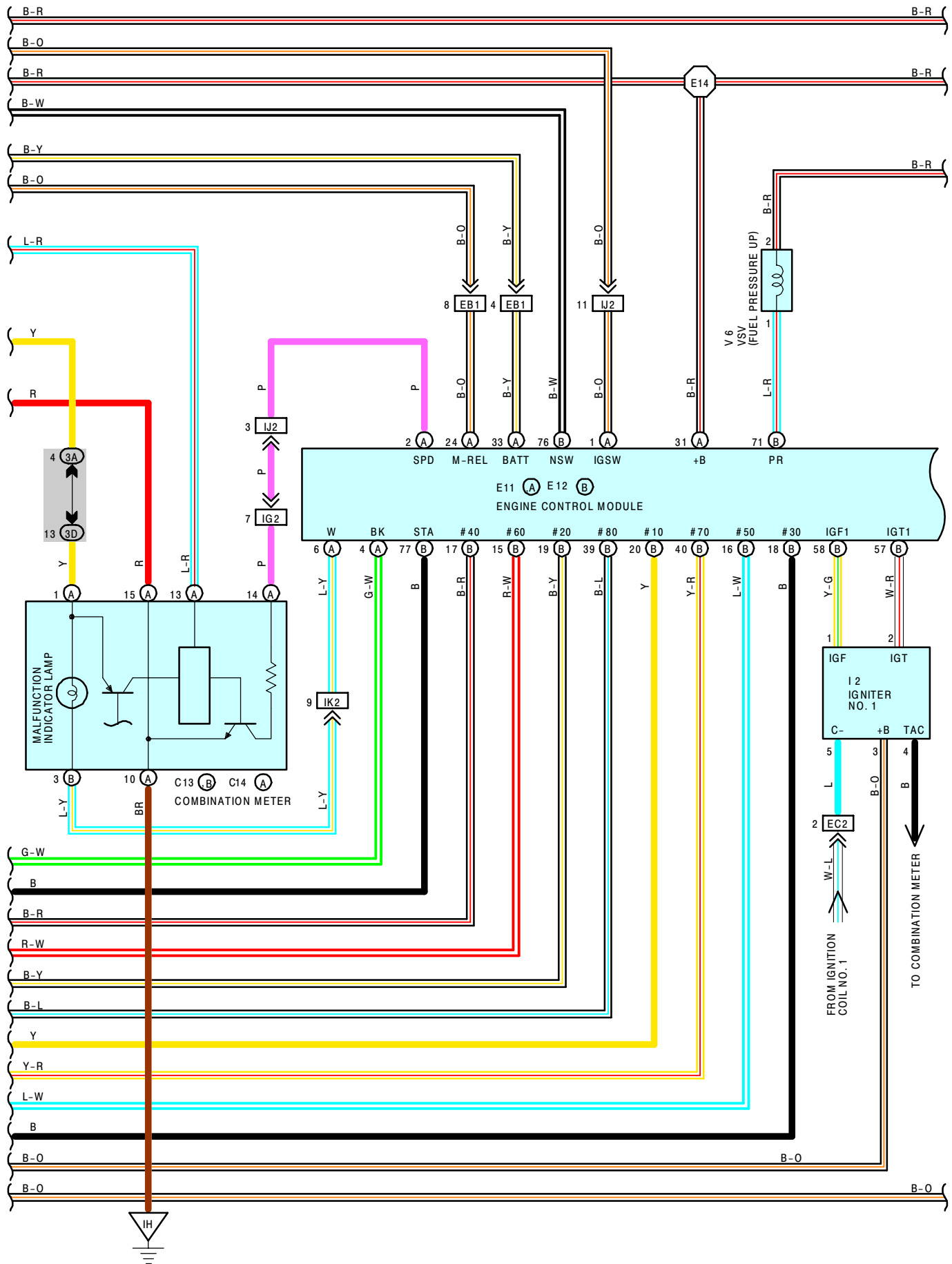

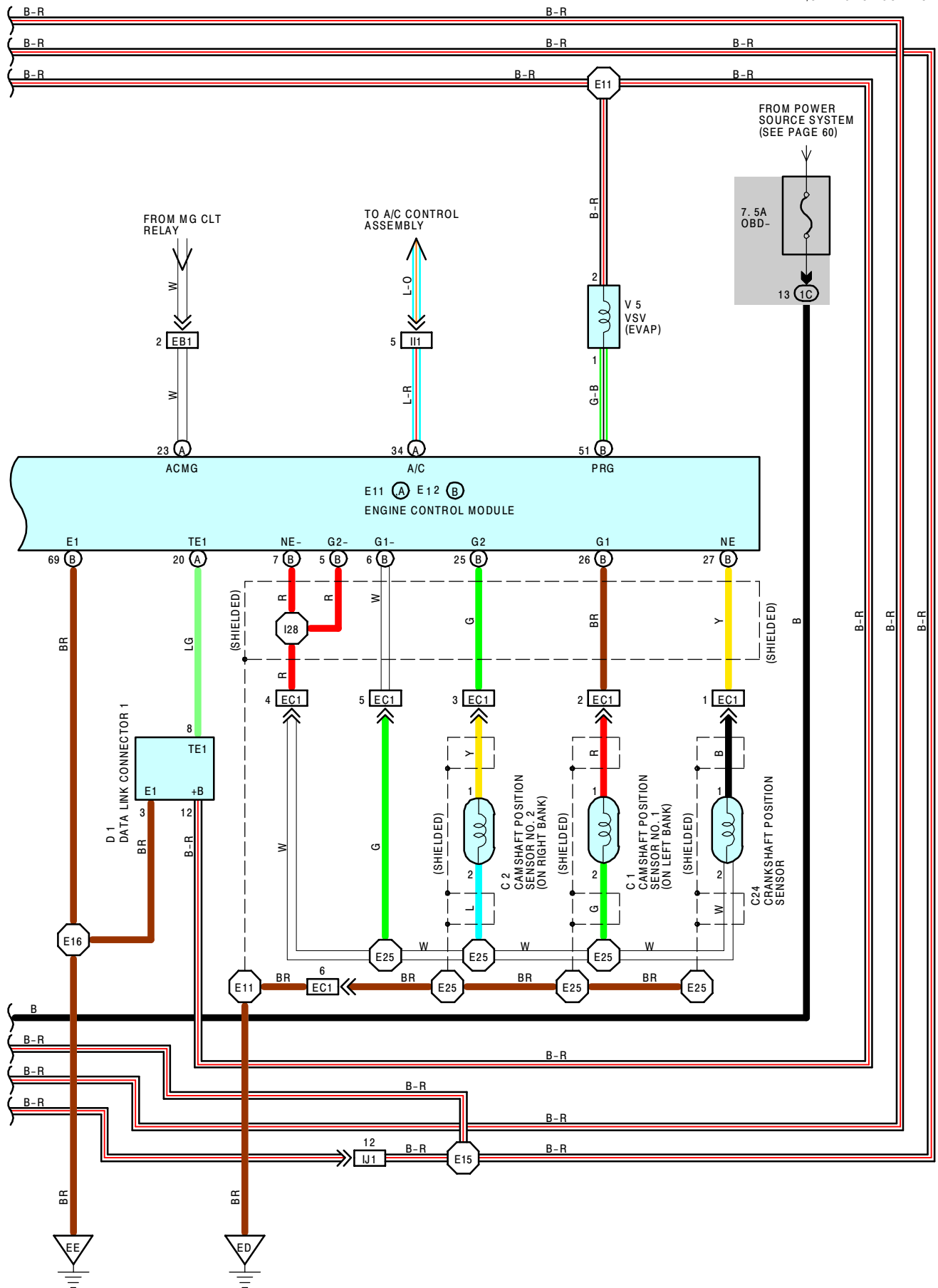



ENGINE CONTROL (1UZ-FE)

SERVICE HINTS

EFI MAIN RELAY

2-4 : CLOSED WITH IGNITION SW AT **ON** OR **ST** POSITION

E 5 ENGINE COOLANT TEMP. SENSOR

1-2 : APPROX. **16 K Ω** (**-20°C, -4°F**)
: APPROX. **2.5 K Ω** (**20°C, 68°F**)
: APPROX. **0.3 K Ω** (**80°C, 176°F**)

E 1 EGR GAS TEMP. SENSOR

1-2 : **69 K Ω -89 K Ω** (**50°C, 122°F**)
12 K Ω -15 K Ω (**100°C, 212°F**)
2 K Ω -4 K Ω (**150°C, 302°F**)

E11, E12 ENGINE CONTROL MODULE

VOLTAGE AT ENGINE CONTROL MODULE WIRING CONNECTOR

BATT -E1 : ALWAYS **9-14 VOLTS**

IGSW, +B -E1 : **9-14 VOLTS** WITH IGNITION SW ON

VC -E2 : **4.5-5.5 VOLTS** WITH IGNITION SW ON

IDL1, IDL2 -E2 : **0-3 VOLTS** WITH IGNITION SW ON AND THROTTLE VALVE FULLY CLOSED

: **9-14 VOLTS** WITH IGNITION SW ON AND THROTTLE VALVE FULLY OPEN

VTA, VTA2 -E2 : **0.3-0.8 VOLTS** WITH IGNITION SW ON AND THROTTLE VALVE FULLY CLOSED

: **3.2-4.9 VOLTS** WITH IGNITION SW ON AND THROTTLE VALVE FULLY OPEN

THA -E2 : **0.5-3.4 VOLTS** WITH IDLING, INTAKE AIR TEMP. **20°C (68°F)**

THW -E2 : **0.2-1.0 VOLTS** WITH IDLING, WATER TEMP. **80°C (176°F)**

STA -E1 : **6.0 VOLTS** OR MORE WITH CLANKING

#10, #20, #30, #40, #50, #60, #70, #80-E01 : **9-14 VOLTS** WITH IGNITION SW ON

: PULSE GENERATION WITH IDLING

IGF1, IGF2 -E1 : BELOW **1 VOLT** WITH IGNITION SW ON

: PULSE GENERATION WITH IDLING

MREL -E1 : **9-14 VOLTS** WITH IGNITION SW ON

DI -E1 : **7.5 VOLTS** OR MORE WITH IDLING

PR -E1 : **9-14 VOLTS** WITH IGNITION SW ON

: **0-3 VOLTS** RESTARTING HIGH TEMP.

PRG -E1 : **9-14 VOLTS** WITH IDLING

ISC, ISC2, ISC3, ISC4-E1 : **9-14 VOLTS** WITH IGNITION SW ON

HLT, HTR, HTL2, HTR2-E01 : **9-14 VOLTS** WITH IGNITION SW ON

EGR1, EGR2, EGR3, EGR4-E1 : **9-14 VOLTS** WITH IGNITION SW ON

NSW -E1 : **0-3 VOLTS** WITH IGNITION SW ON AND SHIFT LEVER "**P**" OR "**N**" POSITION

: **9-14 VOLTS** WITH IGNITION SW ON AND OTHER SHIFT LEVER "**P**" OR "**N**" POSITION

TE1 -E1 : **9-14 VOLTS** WITH IGNITION SW ON

W -E1 : **9-14 VOLTS** WITH IDLING

: **0-3 VOLTS** WITH IGNITION SW ON

AC -E1 : **0-1.5 VOLTS** WITH A/C SW ON (AT IDLING)

: **7.5-14 VOLTS** WITH A/C SW OFF

ACMG-E1 : **0-3 VOLTS** WITH A/C SW ON (AT IDLING)

I 1 IDLE AIR CONTROL VALVE

5-4, 6 : **10 Ω -30 Ω**

2-1, 3 : **10 Ω -30 Ω**

I 6, I 7, I 8, I 9, I 10, I 11, I 12, I 13 INJECTOR

1-2 : **13.4 Ω -14.2 Ω**

H 5, H 6, H 10, H 11 HEATED OXYGEN SENSOR

1-2 : **5 Ω -7 Ω**

T 2 THROTTLE POSITION SENSOR

1-3 : **2.4 K Ω -11.2 K Ω** WITH THROTTLE VALVE FULLY OPEN

0.34 K Ω -6.3 K Ω WITH THROTTLE VALVE FULLY CLOSED

1-2 : LESS THAN **0.5 K Ω** WITH THROTTLE VALVE FULLY CLOSED

1 M Ω OR HIGHER WITH THROTTLE VALVE FULLY OPEN

 : PARTS LOCATION

CODE	SEE PAGE	CODE	SEE PAGE	CODE	SEE PAGE
C 1	26	F15	32	I12	27
C 2	26	H 5	26	I13	27
C13	B 30	H 6	26	I15	31
C14	A 30	H10	31	K 1	27
C24	26	H11	31	K 2	27
D 1	26	I 1	27	M 6	27
D19	28	I 2	27	P 1	27
E 1	26	I 3	27	S13	31
E 2	26	I 6	27	S23	31
E 5	26	I 7	27	T 2	27
E11	A 30	I 8	27	V 1	27
E12	B 30	I 9	27	V 5	27
F 9	26	I10	27	V 6	27
F14	32	I11	27		

 : RELAY BLOCKS

CODE	SEE PAGE	RELAY BLOCKS (RELAY BLOCK LOCATION)
2	19	R/B NO. 2

 : JUNCTION BLOCK AND WIRE HARNESS CONNECTOR

CODE	SEE PAGE	JUNCTION BLOCK AND WIRE HARNESS (CONNECTOR LOCATION)
1B	20	ENGINE ROOM MAIN WIRE AND J/B NO. 1 (LEFT KICK PANEL)
1C	20	FLOOR MAIN WIRE AND J/B NO. 1 (LEFT KICK PANEL)
1E	20	INSTRUMENT PANEL WIRE AND J/B NO. 1 (LEFT KICK PANEL)
1H	20	COWL WIRE AND J/B NO. 1 (LEFT KICK PANEL)
1I		
1J		
1K		
3A	22	INSTRUMENT PANEL WIRE AND J/B NO. 3 (BEHIND THE INSTRUMENT PANEL CENTER)
3D		
3G		

 : CONNECTOR JOINING WIRE HARNESS AND WIRE HARNESS

CODE	SEE PAGE	JOINING WIRE HARNESS AND WIRE HARNESS (CONNECTOR LOCATION)
EB1	36 (1UZ-FE)	ENGINE WIRE AND ENGINE ROOM MAIN WIRE (FRONT SIDE OF R/B NO. 2)
EB2		
EC1	36 (1UZ-FE)	ENGINE WIRE AND ENGINE NO. 4 WIRE (FRONT SIDE OF CYLINDER HEAD COVER LH)
EC2		
ED1	36 (1UZ-FE)	ENGINE NO. 2 WIRE AND ENGINE WIRE (REAR SIDE OF AIR INTAKE CHAMBER)
IE1	40	ENGINE ROOM MAIN WIRE AND COWL WIRE (R/B NO. 4)
IG2	40	INSTRUMENT PANEL WIRE AND COWL WIRE (R/B NO. 5)
IG3	40	INSTRUMENT PANEL WIRE AND COWL WIRE (RIGHT KICK PANEL)
II1	40	ENGINE WIRE AND A/C SUB WIRE (BEHIND GLOVE BOX)
IJ1	40	ENGINE WIRE AND COWL WIRE (RIGHT KICK PANEL)
IJ2		
IK1	40	ENGINE WIRE AND INSTRUMENT PANEL WIRE (RIGHT KICK PANEL)
IK2		
BT1	44	FLOOR MAIN WIRE AND COWL WIRE (LEFT KICK PANEL)
BU1	44	INSTRUMENT PANEL WIRE AND FLOOR MAIN WIRE (LEFT KICK PANEL)

 : GROUND POINTS

CODE	SEE PAGE	GROUND POINTS LOCATION
EB	36 (1UZ-FE)	FRONT SIDE OF LEFT FENDER
ED	36 (1UZ-FE)	REAR SIDE OF CYLINDER HEAD RH
EE	36 (1UZ-FE)	REAR SIDE OF CYLINDER HEAD LH
IF	40	LEFT KICK PANEL
IH	40	UNDER THE ASHTRAY LH
BK	44	UNDER THE CENTER PILLAR LH



ENGINE CONTROL (1UZ-FE)

 : SPLICE POINTS

CODE	SEE PAGE	WIRE HARNESS WITH SPLICE POINTS	CODE	SEE PAGE	WIRE HARNESS WITH SPLICE POINTS
E 8	36 (1UZ-FE)	ENGINE ROOM MAIN WIRE	I13	42	COWL WIRE
E11	36 (1UZ-FE)	ENGINE WIRE	I18	42	INSTRUMENT PANEL WIRE
E12			I19	42	COWL WIRE
E13			I20	42	INSTRUMENT PANEL WIRE
E14			I21	42	COWL WIRE
E15			I25	42	ENGINE WIRE
E16			I26		
E25	36 (1UZ-FE)	ENGINE NO. 4 WIRE	I28		
I 9	42	INSTRUMENT PANEL WIRE	I35	42	INSTRUMENT PANEL WIRE
I10			B18	44	FLOOR MAIN WIRE

C 1 DARK GRAY



C 2 DARK GRAY



C13 (B)

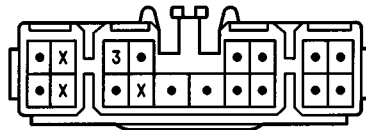

C14 (A)

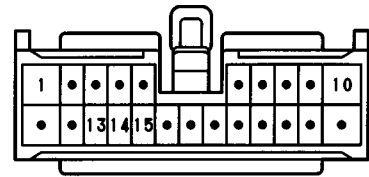

C24 DARK GRAY



D 1 BLACK

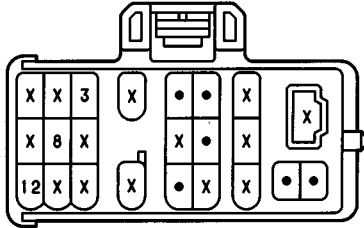

D19

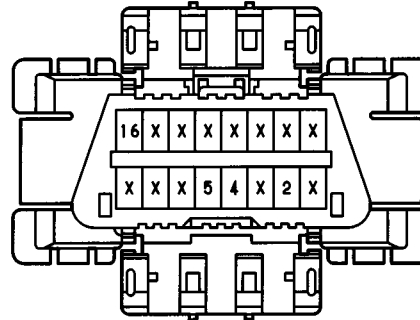

E 1 DARK GRAY



E 2 DARK GRAY



E 5 GREEN



E11 (A) DARK GRAY

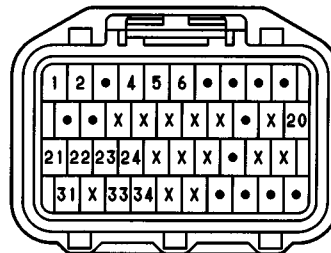

E12 **B** DARK GRAY

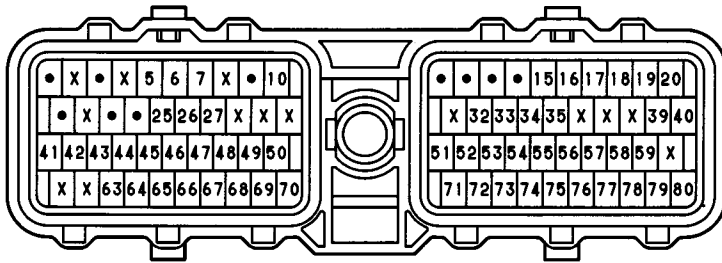

F 9

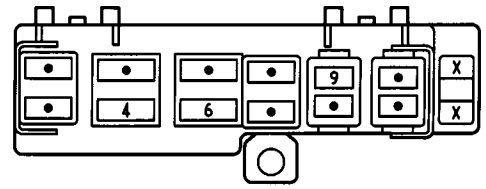

F14 DARK GRAY

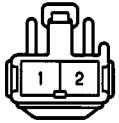

F15 BLACK

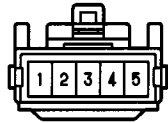

H 5, H 6 DARK GRAY



H10, H11 DARK GRAY



I 1 DARK GRAY



I 2 BLACK

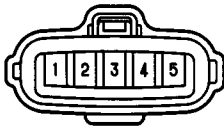

I 3 BLACK

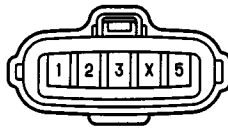

I 6, I 7, I 8, I 9, I 10, I 11, I 12, I 13 BLUE



I 16

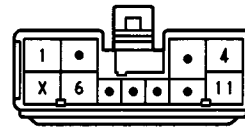

K 1, K 2 DARK GRAY



M 6 BLACK



P 1 GRAY

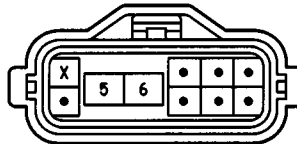

S13

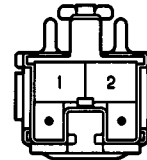

S23



T 2 BLACK



V 1 GRAY



V 5 BLACK

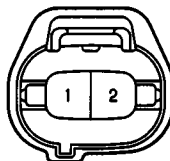

V 6 BLACK

